

Nivz Valves & Automation

Ball Valve, 1Pc. Screwed (BSP/NPT), 150#

DRG. No.: SXV11

00

Rev. No.

FEATURES

- * Fire Safe Design [Optional]
- * Low Operating Torque
- * Leak Tight Stem Sealing
- * Pneumatic Operation Optional

Pressure Rating : 150 #
 End Connection : SCREWED END [BSP/NPT]
 : SOCKET WELD END
 Screwed End : AS PER ASME B 1.20.1(BSP/NPT)
 Socket Weld End : AS PER ANSI B 16.11
 Operation : Manual Hand Lever Operated

Nomenclature:-

NO.	PART NAME	MATERIAL
1	Body	A 351 GR. CF8/CF8M/CF3/CF 3M
2	Side Piece	
3	Ball	AISI 304/316/304L/316L/CF8/8M/3/3M Solid Ball Up To 20NB & Above Hollow Ball
4	Stem	AISI 304/316/304L/316L
5	Ball Seat	P.T.F.E.(VIRGIN)/GFT/CARBON FILLED
6	Body Seal	P.T.F.E.(VIRGIN)/GFT/CARBON FILLED
7	Gland Seal	P.T.F.E.(VIRGIN)/GFT/CARBON FILLED
8	Gland Bush	AISI 304/316/304L/316L
9	Gland Nut	C.S./194 GR. 2H/S.S. 304/316
10	Hand Lever	CARBON STEEL/S.S.
11	Hand Lever Nut	C.S./194 GR. 2H/S.S. 304/316
12	Lever Sleeve	P.V.C.

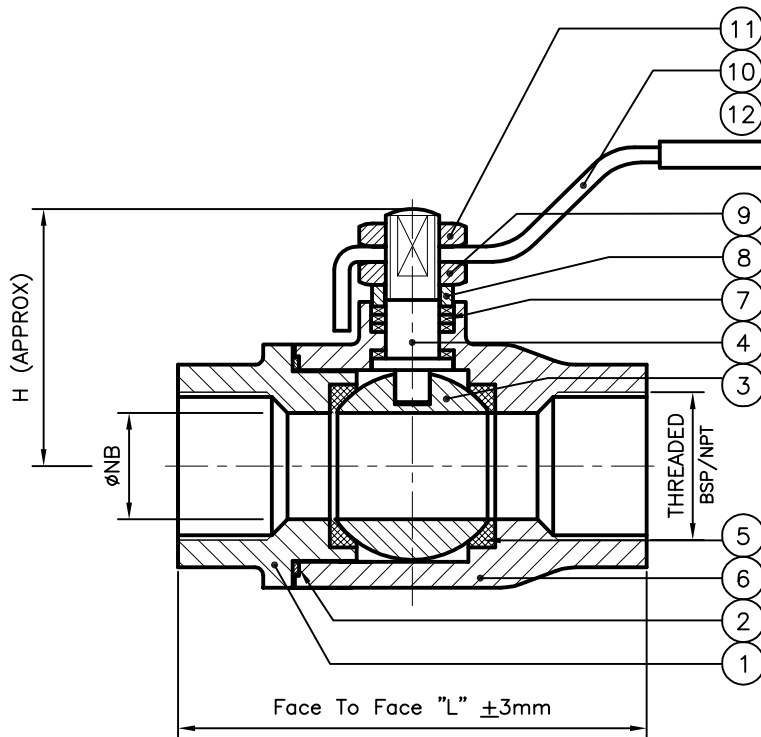

Design Standard : BS 5351/ASME B 16.34

Dimensions [150 Class]

SIZE	6	10	15	20	25	32	40	50	65	80	100
L	56	56	63	70	80	90	104	119	142	158	178
øA	---	---	21.7	27.1	33.8	43.2	48.6	61.1	73.5	90.5	116.1
øNB	9.5	9.5	12.7	19	25	32	38	50	63	75	100
H	38	38	41	49	58	72	77	86	102	112	145

All Dimensions Are In mm

Testing Standard : BS 6755-I

Test Pressure in PSIG/BAR/KG./CM²

Test	Hydrostatic		Air	
	Pr. Rating	150#		
Body	425	29.3	30	
Seat	300	20.7	21	80 5.5 5.6



VALVES & AUTOMATION
www.nivzvalves.com

Client _____

Order / Enq. No. _____

Job / Project _____

Manufactured By : **Nivz Valves & Automation**, Ahmedabad, Gujarat, INDIA.

Due to continuous development programme, the design and data given in this leaflet are subject to change without prior notice

Appd. _____

Chkd. _____

Drwn. _____

For Record

For Reference

For Approval